

T1A01 (D) [97.3(a)(4)]

For whom is the Amateur Radio Service intended?

D. Persons who are interested in radio technique solely with a personal aim and without pecuniary interest

T1A02 (C) [97.1]

What agency regulates and enforces the rules for the Amateur Radio Service in the United States?

C. The FCC

T1A03 (D)

Which part of the FCC rules contains the rules and regulations governing the Amateur Radio Service?

D. Part 97

T1A04 (C) [97.3(a)(23)]

Which of the following meets the FCC definition of harmful interference?

C. That which seriously degrades, obstructs, or repeatedly interrupts a radio communication service operating in accordance with the Radio Regulations

T1A05 (D) [97.3(a)(40)]

What is the FCC Part 97 definition of a space station?

D. An amateur station located more than 50 km above the Earth's surface

T1A06 (C) [97.3(a)(43)]

What is the FCC Part 97 definition of telecommand?

C. A one-way transmission to initiate, modify or terminate functions of a device at a distance

T1A07 (C) [97.3(a)(45)]

What is the FCC Part 97 definition of telemetry?

C. A one-way transmission of measurements at a distance from the measuring instrument

T1A08 (B) [97.3(a)(22)]

Which of the following entities recommends transmit/receive channels and other parameters for auxiliary and repeater stations?

B. Frequency Coordinator

T1A09 (C) [97.3(a)(22)]

Who selects a Frequency Coordinator?

C. Amateur operators in a local or regional area whose stations are eligible to be auxiliary or repeater stations

T1A10 (A) [97.3(a)(5)]

What is the FCC Part 97 definition of an amateur station?

A. A station in an Amateur Radio Service consisting of the apparatus necessary for carrying on radio communications

T1A11 (C) [97.3(a)(7)]

Which of the following stations transmits signals over the air from a remote receive site to a repeater for retransmission?

C. Auxiliary station

T1B01 (B) [97.3(a)(28)]

What is the ITU?

B. A United Nations agency for information and communication technology issues

T1B02 (B)

North American amateur stations are located in which ITU region?

B. Region 2

T1B03 (B) [97.301(a)]

Which frequency is within the 6 meter band?

B. 52.525 MHz

T1B04 (A) [97.301(a)]

Which amateur band are you using when your station is transmitting on 146.52 MHz?

A. 2 meter band

T1B05 (C) [97.301(a)]

Which 70 cm frequency is authorized to a Technician Class license holder operating in ITU Region 2?

C. 443.350 MHz

T1B06 (B) [97.301(a)]

Which 23 cm frequency is authorized to a Technician Class operator license?

B. 1296 MHz

T1B07 (D) [97.301(a)]

What amateur band are you using if you are transmitting on 223.50 MHz?

D. 1.25 meter band

T1B08 (C) [97.303]

What do the FCC rules mean when an amateur frequency band is said to be available on a secondary basis?

C. Amateurs may not cause harmful interference to primary users

T1B09 (D) [97.101(a)]

Why should you not set your transmit frequency to be exactly at the edge of an amateur band or sub-band?

D. All of these choices are correct

T1B10 (C) [97.305(c)]

Which of the bands available to Technician Class operators have mode-restricted sub-bands?

C. The 6 meter, 2 meter, and 1.25 meter bands

T1B11 (A) [97.305 (a)(c)]

What emission modes are permitted in the mode-restricted sub-bands at 50.0 to 50.1 MHz and 144.0 to 144.1 MHz?

A. CW only

T1C01 (C) [97.3(a)(11)(iii)]

Which type of call sign has a single letter in both the prefix and suffix?

C. Special event

T1C02 (B)

Which of the following is a valid US amateur radio station call sign?

B. W3ABC

T1C03 (A) [97.117]

What types of international communications are permitted by an FCC-licensed amateur station?

A. Communications incidental to the purposes of the amateur service and remarks of a personal character

T1C04 (A)

When are you allowed to operate your amateur station in a foreign country?

A. When the foreign country authorizes it

T1C05 (A) [97.303(h)]

What must you do if you are operating on the 23 cm band and learn that you are interfering with a radiolocation station outside the United States?

A. Stop operating or take steps to eliminate the harmful interference

T1C06 (D) [97.5(a)(2)]

From which of the following may an FCC-licensed amateur station transmit, in addition to places where the FCC regulates communications?

D. From any vessel or craft located in international waters and documented or registered in the United States

T1C07 (B) [97.23]

What may result when correspondence from the FCC is returned as undeliverable because the grantee failed to provide the correct mailing address?

B. Revocation of the station license or suspension of the operator license

T1C08 (C) [97.25]

What is the normal term for an FCC-issued primary station/operator license grant?

C. Ten years

T1C09 (A) [97.21(a)(b)]

What is the grace period following the expiration of an amateur license within which the license may be renewed?

A. Two years

T1C10 (C) [97.5a]

How soon may you operate a transmitter on an amateur service frequency after you pass the examination required for your first amateur radio license?

C. As soon as your name and call sign appear in the FCC's ULS database

T1C11 (A) [97.21(b)]

If your license has expired and is still within the allowable grace period, may you continue to operate a transmitter on amateur service frequencies?

A. No, transmitting is not allowed until the ULS database shows that the license has been renewed

T1D01 (A) [97.111(a)(1)]

With which countries are FCC-licensed amateur stations prohibited from exchanging communications?

A. Any country whose administration has notified the ITU that it objects to such communications

T1D02 (A) [97.111(a)(5)]

On which of the following occasions may an FCC-licensed amateur station exchange messages with a U.S. military station?

A. During an Armed Forces Day Communications Test

T1D03 (C) [97.113(a)(4), 97.211(b), 97.217]

When is the transmission of codes or ciphers allowed to hide the meaning of a message transmitted by an amateur station?

C. Only when transmitting control commands to space stations or radio control craft

T1D04 (A) [97.113(a)(4), 97.113(e)]

What is the only time an amateur station is authorized to transmit music?

A. When incidental to an authorized retransmission of manned spacecraft communications

T1D05 (A) [97.113(a)(3)]

When may amateur radio operators use their stations to notify other amateurs of the availability of equipment for sale or trade?

A. When the equipment is normally used in an amateur station and such activity is not conducted on a regular basis

T1D06 (A) [97.113(a)(4)]

Which of the following types of transmissions are prohibited?

A. Transmissions that contain obscene or indecent words or language

T1D07 (B) [97.113(f)]

When is an amateur station authorized to automatically retransmit the radio signals of other amateur stations?

B. When the signals are from an auxiliary, repeater, or space station

T1D08 (B) [97.113]

When may the control operator of an amateur station receive compensation for operating the station?

B. When the communication is incidental to classroom instruction at an educational institution

T1D09 (A) [97.113(b)]

Under which of the following circumstances are amateur stations authorized to transmit signals related to broadcasting, program production, or news gathering, assuming no other means is available?

A. Only where such communications directly relate to the immediate safety of human life or protection of property

T1D10 (D) [97.3(a)(10)]

What is the meaning of the term broadcasting in the FCC rules for the amateur services?

D. Transmissions intended for reception by the general public

T1D11 (A) [97.113(a)(5)]

Which of the following types of communications are permitted in the Amateur Radio Service?

A. Brief transmissions to make station adjustments

T1E01 (A) [97.7(a)]

When must an amateur station have a control operator?

A. Only when the station is transmitting

T1E02 (D) [97.7(a)]

Who is eligible to be the control operator of an amateur station?

D. Only a person for whom an amateur operator/primary station license grant appears in the FCC database or who is authorized for alien reciprocal operation

T1E03 (A) [97.103(b)]

Who must designate the station control operator?

A. The station licensee

T1E04 (D) [97.103(b)]

What determines the transmitting privileges of an amateur station?

D. The class of operator license held by the control operator

T1E05 (C) [97.3(a)(14)]

What is an amateur station control point?

C. The location at which the control operator function is performed

T1E06 (B) [97.109(d)]

Under which of the following types of control is it permissible for the control operator to be at a location other than the control point?

B. Automatic control

T1E07 (D) [97.103(a)]

When the control operator is not the station licensee, who is responsible for the proper operation of the station?

D. The control operator and the station licensee are equally responsible

T1E08 (C) [97.3(a)]

What type of control is being used for a repeater when the control operator is not present at a control point?

C. Automatic control

T1E09 (D) [97.109(a)]

What type of control is being used when transmitting using a handheld radio?

D. Local control

T1E10 (B) [97.3]

What type of control is used when the control operator is not at the station location but can indirectly manipulate the operating adjustments of a station?

B. Remote

T1E11 (D) [97.103(a)]

Who does the FCC presume to be the control operator of an amateur station, unless documentation to the contrary is in the station records?

D. The station licensee

T1F01 (A)

What type of identification is being used when identifying a station on the air as "Race Headquarters"?

A. Tactical call

T1F02 (C) [97.119 (a)]

When using tactical identifiers, how often must your station transmit the station's FCC-assigned call sign?

C. Every ten minutes

T1F03 (D) [97.119(a)]

When is an amateur station required to transmit its assigned call sign?

D. At least every 10 minutes during and at the end of a contact

T1F04 (C) [97.119(b)]

Which of the following is an acceptable language for use for station identification when operating in a phone sub-band?

C. The English language

T1F05 (B) [97.119(b)]

What method of call sign identification is required for a station transmitting phone signals?

B. Send the call sign using CW or phone emission

T1F06 (D) [97.119(c)]

Which of the following formats of a self-assigned indicator is acceptable when identifying using a phone transmission?

D. All of these choices are correct

T1F07 (D) [97.119(c)]

Which of the following restrictions apply when appending a self-assigned call sign indicator?

D. It must not conflict with any other indicator specified by the FCC rules or with any call sign prefix assigned to another country

T1F08 (A) [97.119(e)]

When may a Technician Class licensee be the control operator of a station operating in an exclusive Extra Class operator segment of the amateur bands?

A. Never

T1F09 (C) [97.3(a)(39)]

What type of amateur station simultaneously retransmits the signal of another amateur station on a different channel or channels?

C. Repeater station

T1F10 (A) [97.205(g)]

Who is accountable should a repeater inadvertently retransmit communications that violate the FCC rules?

A. The control operator of the originating station

T1F11 (A) [97.115(a)]

To which foreign stations do the FCC rules authorize the transmission of non-emergency third party communications?

A. Any station whose government permits such communications

T1F12 (B) [97.5(b)(2)]

How many persons are required to be members of a club for a club station license to be issued by the FCC?

B. At least 4

T1F13 (B) [97.103(c)]

When must the station licensee make the station and its records available for FCC inspection?

B. Any time upon request by an FCC representative

T2A01 (B)

What is the most common repeater frequency offset in the 2 meter band?

B. plus or minus 600 kHz

T2A02 (D)

What is the national calling frequency for FM simplex operations in the 70 cm band?

D. 446.000 MHz

T2A03 (A)

What is a common repeater frequency offset in the 70 cm band?

A. Plus or minus 5 MHz

T2A04 (B)

What is an appropriate way to call another station on a repeater if you know the other station's call sign?

B. Say the station's call sign then identify with your call sign

T2A05 (C)

What should you transmit when responding to a call of CQ?

C. The other station's call sign followed by your call sign

T2A06 (A)

What must an amateur operator do when making on-air transmissions to test equipment or antennas?

A. Properly identify the transmitting station

T2A07 (D)

Which of the following is true when making a test transmission?

D. Station identification is required at least every ten minutes during the test and at the end

T2A08 (D)

What is the meaning of the procedural signal "CQ"?

D. Calling any station

T2A09 (B)

What brief statement is often used in place of "CQ" to indicate that you are listening on a repeater?

B. Say your call sign

T2A10 (A)

What is a band plan, beyond the privileges established by the FCC?

A. A voluntary guideline for using different modes or activities within an amateur band

T2A11 (D) [97.313(a)]

What are the FCC rules regarding power levels used in the amateur bands?

D. An amateur must use the minimum transmitter power necessary to carry out the desired communication

T2B01 (C)

What is the term used to describe an amateur station that is transmitting and receiving on the same frequency?

C. Simplex communication

T2B02 (D)

What is the term used to describe the use of a sub-audible tone transmitted with normal voice audio to open the squelch of a receiver?

D. CTCSS

T2B03 (B)

Which of the following describes the muting of receiver audio controlled solely by the presence or absence of an RF signal?

B. Carrier squelch

T2B04 (D)

Which of the following common problems might cause you to be able to hear but not access a repeater even when transmitting with the proper offset?

D. All of these choices are correct

T2B05 (C)

What determines the amount of deviation of an FM signal?

C. The amplitude of the modulating signal

T2B06 (A)

What happens when the deviation of an FM transmitter is increased?

A. Its signal occupies more bandwidth

T2B07 (D)

What should you do if you receive a report that your station's transmissions are causing splatter or interference on nearby frequencies?

D. Check your transmitter for off-frequency operation or spurious emissions

T2B08 (B)

What is the proper course of action if your station's transmission unintentionally interferes with another station?

B. Properly identify your transmission and move to a different frequency

T2B09 (A) [97.119(b)(2)]

Which of the following methods is encouraged by the FCC when identifying your station when using phone?

A. Use of a phonetic alphabet

T2B10 (A)

What is the "Q" signal used to indicate that you are receiving interference from other stations?

A. QRM

T2B11 (B)

What is the "Q" signal used to indicate that you are changing frequency?

B. QSY

T2C01 (C) [97.103(a)]

What set of rules applies to proper operation of your station when using amateur radio at the request of public service officials?

C. FCC Rules

T2C02 (D) [97.113 and FCC Public Notice DA 09-2259]

Who must submit the request for a temporary waiver of Part 97.113 to allow amateur radio operators to provide communications on behalf of their employers during a government sponsored disaster drill?

D. The government agency sponsoring the event

T2C03 (C) [97.113]

When is it legal for an amateur licensee to provide communications on behalf of their employer during a government sponsored disaster drill or exercise?

C. Only when the FCC has granted a government-requested waiver

T2C04 (D)

What do RACES and ARES have in common?

D. Both organizations may provide communications during emergencies

T2C05 (B) [97.3(a)(37), 97.407 ]

What is the Radio Amateur Civil Emergency Service?

B. A radio service using amateur stations for emergency management or civil defense communications

T2C06 (C)

Which of the following is common practice during net operations to get the immediate attention of the net control station when reporting an emergency?

C. Begin your transmission with "Priority" or "Emergency" followed by your call sign

T2C07 (C)

What should you do to minimize disruptions to an emergency traffic net once you have checked in?

C. Do not transmit on the net frequency until asked to do so by the net control station

T2C08 (A)

What is usually considered to be the most important job of an amateur operator when handling emergency traffic messages?

A. Passing messages exactly as written, spoken or as received

T2C09 (B) [97.403]

When may an amateur station use any means of radio communications at its disposal for essential communications in connection with immediate safety of human life and protection of property?

B. When normal communications systems are not available

T2C10 (D)

What is the preamble in a formal traffic message?

D. The information needed to track the message as it passes through the amateur radio traffic handling system

T2C11 (A)

What is meant by the term "check" in reference to a formal traffic message?

A. The check is a count of the number of words or word equivalents in the text portion of the message

T3A01 (D)

What should you do if another operator reports that your station's 2 meter signals were strong just a moment ago, but now they are weak or distorted?

D. Try moving a few feet, as random reflections may be causing multi-path distortion

T3A02 (B)

Why are UHF signals often more effective from inside buildings than VHF signals?

B. The shorter wavelength allows them to more easily penetrate the structure of buildings

T3A03 (C)

What antenna polarization is normally used for long-distance weak-signal CW and SSB contacts using the VHF and UHF bands?

C. Horizontal

T3A04 (B)

What can happen if the antennas at opposite ends of a VHF or UHF line of sight radio link are not using the same polarization?

B. Signals could be significantly weaker

T3A05 (B)

When using a directional antenna, how might your station be able to access a distant repeater if buildings or obstructions are blocking the direct line of sight path?

B. Try to find a path that reflects signals to the repeater

T3A06 (B)

What term is commonly used to describe the rapid fluttering sound sometimes heard from mobile stations that are moving while transmitting?

B. Picket fencing

T3A07 (A)

What type of wave carries radio signals between transmitting and receiving stations?

A. Electromagnetic

T3A08 (C)

What is the cause of irregular fading of signals from distant stations during times of generally good reception?

C. Random combining of signals arriving via different path lengths

T3A09 (B)

Which of the following is a common effect of "skip" reflections between the Earth and the ionosphere?

B. The polarization of the original signal is randomized

T3A10 (D)

What may occur if VHF or UHF data signals propagate over multiple paths?

D. Error rates are likely to increase

T3A11 (C)

Which part of the atmosphere enables the propagation of radio signals around the world?

C. The ionosphere

T3B01 (C)

What is the name for the distance a radio wave travels during one complete cycle?

C. Wavelength

T3B02 (D)

What term describes the number of times per second that an alternating current reverses direction?

D. Frequency

T3B03 (C)

What are the two components of a radio wave?

C. Electric and magnetic fields

T3B04 (A)

How fast does a radio wave travel through free space?

A. At the speed of light

T3B05 (B)

How does the wavelength of a radio wave relate to its frequency?

B. The wavelength gets shorter as the frequency increases

T3B06 (D)

What is the formula for converting frequency to wavelength in meters?

D. Wavelength in meters equals 300 divided by frequency in megahertz

T3B07 (A)

What property of radio waves is often used to identify the different frequency bands?

A. The approximate wavelength

T3B08 (B)

What are the frequency limits of the VHF spectrum?

B. 30 to 300 MHz

T3B09 (D)

What are the frequency limits of the UHF spectrum?

D. 300 to 3000 MHz

T3B10 (C)

What frequency range is referred to as HF?

C. 3 to 30 MHz

T3B11 (B)

What is the approximate velocity of a radio wave as it travels through free space?

B. 300,000,000 meters per second

T3C01 (C)

Why are "direct" (not via a repeater) UHF signals rarely heard from stations outside your local coverage area?

C. UHF signals are usually not reflected by the ionosphere

T3C02 (D)

Which of the following might be happening when VHF signals are being received from long distances?

D. Signals are being refracted from a sporadic E layer

T3C03 (B)

What is a characteristic of VHF signals received via auroral reflection?

B. The signals exhibit rapid fluctuations of strength and often sound distorted

T3C04 (B)

Which of the following propagation types is most commonly associated with occasional strong over-the-horizon signals on the 10, 6, and 2 meter bands?

B. Sporadic E

T3C05 (C)

What is meant by the term "knife-edge" propagation?

C. Signals are partially refracted around solid objects exhibiting sharp edges

T3C06 (A)

What mode is responsible for allowing over-the-horizon VHF and UHF communications to ranges of approximately 300 miles on a regular basis?

A. Tropospheric scatter

T3C07 (B)

What band is best suited to communicating via meteor scatter?

B. 6 meters

T3C08 (D)

What causes "tropospheric ducting"?

D. Temperature inversions in the atmosphere

T3C09 (A)

What is generally the best time for long-distance 10 meter band propagation?

A. During daylight hours

T3C10 (A)

What is the radio horizon?

A. The distance at which radio signals between two points are effectively blocked by the curvature of the Earth

T3C11 (C)

Why do VHF and UHF radio signals usually travel somewhat farther than the visual line of sight distance between two stations?

C. The Earth seems less curved to radio waves than to light

T4A01 (B)

Which of the following is true concerning the microphone connectors on amateur transceivers?

B. Some connectors include push-to-talk and voltages for powering the microphone

T4A02 (C)

What could be used in place of a regular speaker to help you copy signals in a noisy area?

C. A set of headphones

T4A03 (A)

Which is a good reason to use a regulated power supply for communications equipment?

A. It prevents voltage fluctuations from reaching sensitive circuits

T4A04 (A)

Where must a filter be installed to reduce harmonic emissions?

A. Between the transmitter and the antenna

T4A05 (D)

What type of filter should be connected to a TV receiver as the first step in trying to prevent RF overload from a nearby 2 meter transmitter?

D. Band-reject filter

T4A06 (C)

Which of the following would be connected between a transceiver and computer in a packet radio station?

C. Terminal node controller

T4A07 (C)

How is the computer's sound card used when conducting digital communications using a computer?

C. The sound card provides audio to the microphone input and converts received audio to digital form

T4A08 (D)

Which type of conductor is best to use for RF grounding?

D. Flat strap

T4A09 (D)

Which would you use to reduce RF current flowing on the shield of an audio cable?

D. Ferrite choke

T4A10 (B)

What is the source of a high-pitched whine that varies with engine speed in a mobile transceiver's receive audio?

B. The alternator

T4A11 (A)

Where should a mobile transceiver's power negative connection be made?

A. At the battery or engine block ground strap

T4B01 (B)

What may happen if a transmitter is operated with the microphone gain set too high?

B. The output signal might become distorted

T4B02 (A)

Which of the following can be used to enter the operating frequency on a modern transceiver?

A. The keypad or VFO knob

T4B03 (D)

What is the purpose of the squelch control on a transceiver?

D. To mute receiver output noise when no signal is being received

T4B04 (B)

What is a way to enable quick access to a favorite frequency on your transceiver?

B. Store the frequency in a memory channel

T4B05 (C)

Which of the following would reduce ignition interference to a receiver?

C. Turn on the noise blanker

T4B06 (D)

Which of the following controls could be used if the voice pitch of a single-sideband signal seems too high or low?

D. The receiver RIT or clarifier

T4B07 (B)

What does the term "RIT" mean?

B. Receiver Incremental Tuning

T4B08 (B)

What is the advantage of having multiple receive bandwidth choices on a multimode transceiver?

B. Permits noise or interference reduction by selecting a bandwidth matching the mode

T4B09 (C)

Which of the following is an appropriate receive filter to select in order to minimize noise and interference for SSB reception?

C. 2400 Hz

T4B10 (A)

Which of the following is an appropriate receive filter to select in order to minimize noise and interference for CW reception?

A. 500 Hz

T4B11 (C)

Which of the following describes the common meaning of the term "repeater offset"?

C. The difference between the repeater's transmit and receive frequencies

T5A01 (D)

Electrical current is measured in which of the following units?

D. Amperes

T5A02 (B)

Electrical power is measured in which of the following units?

B. Watts

T5A03 (D)

What is the name for the flow of electrons in an electric circuit?

D. Current

T5A04 (B)

What is the name for a current that flows only in one direction?

B. Direct current

T5A05 (A)

What is the electrical term for the electromotive force (EMF) that causes electron flow?

A. Voltage

T5A06 (A)

How much voltage does a mobile transceiver usually require?

A. About 12 volts

T5A07 (C)

Which of the following is a good electrical conductor?

C. Copper

T5A08 (B)

Which of the following is a good electrical insulator?

B. Glass

T5A09 (A)

What is the name for a current that reverses direction on a regular basis?

A. Alternating current

T5A10 (C)

Which term describes the rate at which electrical energy is used?

C. Power

T5A11 (A)

What is the basic unit of electromotive force?

A. The volt

T5B01 (C)

How many milliamperes is 1.5 amperes?

C. 1,500 milliamperes

T5B02 (A)

What is another way to specify a radio signal frequency of 1,500,000 hertz?

A. 1500 kHz

T5B03 (C)

How many volts are equal to one kilovolt?

C. One thousand volts

T5B04 (A)

How many volts are equal to one microvolt?

A. One one-millionth of a volt

T5B05 (B)

Which of the following is equivalent to 500 milliwatts?

B. 0.5 watts

T5B06 (C)

If an ammeter calibrated in amperes is used to measure a 3000-milliampere current, what reading would it show?

C. 3 amperes

T5B07 (C)

If a frequency readout calibrated in megahertz shows a reading of 3.525 MHz, what would it show if it were calibrated in kilohertz?

C. 3525 kHz

T5B08 (B)

How many microfarads are 1,000,000 picofarads?

B. 1 microfarad

T5B09 (B)

What is the approximate amount of change, measured in decibels (dB), of a power increase from 5 watts to 10 watts?

B. 3 dB

T5B10 (C)

What is the approximate amount of change, measured in decibels (dB), of a power decrease from 12 watts to 3 watts?

C. 6 dB

T5B11 (A)

What is the approximate amount of change, measured in decibels (dB), of a power increase from 20 watts to 200 watts?

A. 10 dB

T5C01 (D)

What is the ability to store energy in an electric field called?

D. Capacitance

T5C02 (A)

What is the basic unit of capacitance?

A. The farad

T5C03 (D)

What is the ability to store energy in a magnetic field called?

D. Inductance

T5C04 (C)

What is the basic unit of inductance?

C. The henry

T5C05 (A)

What is the unit of frequency?

A. Hertz

T5C06 (C)

What is the abbreviation that refers to radio frequency signals of all types?

C. RF

T5C07 (C)

What is a usual name for electromagnetic waves that travel through space?

C. Radio waves

T5C08 (A)

What is the formula used to calculate electrical power in a DC circuit?

A. Power (P) equals voltage (E) multiplied by current (I)

T5C09 (A)

How much power is being used in a circuit when the applied voltage is 13.8 volts DC and the current is 10 amperes?

A. 138 watts

T5C10 (B)

How much power is being used in a circuit when the applied voltage is 12 volts DC and the current is 2.5 amperes?

B. 30 watts

T5C11 (B)

How many amperes are flowing in a circuit when the applied voltage is 12 volts DC and the load is 120 watts?

B. 10 amperes

T5D01 (B)

What formula is used to calculate current in a circuit?

B. Current (I) equals voltage (E) divided by resistance (R)

T5D02 (A)

What formula is used to calculate voltage in a circuit?

A. Voltage (E) equals current (I) multiplied by resistance (R)

T5D03 (B)

What formula is used to calculate resistance in a circuit?

B. Resistance (R) equals voltage (E) divided by current (I)

T5D04 (B)

What is the resistance of a circuit in which a current of 3 amperes flows through a resistor connected to 90 volts?

B. 30 ohms

T5D05 (C)

What is the resistance in a circuit for which the applied voltage is 12 volts and the current flow is 1.5 amperes?

C. 8 ohms

T5D06 (A)

What is the resistance of a circuit that draws 4 amperes from a 12-volt source?

A. 3 ohms

T5D07 (D)

What is the current flow in a circuit with an applied voltage of 120 volts and a resistance of 80 ohms?

D. 1.5 amperes

T5D08 (C)

What is the current flowing through a 100-ohm resistor connected across 200 volts?

C. 2 amperes

T5D09 (C)

What is the current flowing through a 24-ohm resistor connected across 240 volts?

C. 10 amperes

T5D10 (A)

What is the voltage across a 2-ohm resistor if a current of 0.5 amperes flows through it?

A. 1 volt

T5D11 (B)

What is the voltage across a 10-ohm resistor if a current of 1 ampere flows through it?

B. 10 volts

T5D12 (D)

What is the voltage across a 10-ohm resistor if a current of 2 amperes flows through it?

D. 20 volts

T6A01 (B)

What electrical component is used to oppose the flow of current in a DC circuit?

B. Resistor

T6A02 (C)

What type of component is often used as an adjustable volume control?

C. Potentiometer

T6A03 (B)

What electrical parameter is controlled by a potentiometer?

B. Resistance

T6A04 (B)

What electrical component stores energy in an electric field?

B. Capacitor

T6A05 (D)

What type of electrical component consists of two or more conductive surfaces separated by an insulator?

D. Capacitor

T6A06 (C)

What type of electrical component stores energy in a magnetic field?

C. Inductor

T6A07 (D)

What electrical component is usually composed of a coil of wire?

D. Inductor

T6A08 (B)

What electrical component is used to connect or disconnect electrical circuits?

B. Switch

T6A09 (A)

What electrical component is used to protect other circuit components from current overloads?

A. Fuse

T6A10 (B)

What is the nominal voltage of a fully charged nickel-cadmium cell?

B. 1.2 volts

T6A11 (B)

Which battery type is not rechargeable?

B. Carbon-zinc

T6B01 (D)

What class of electronic components is capable of using a voltage or current signal to control current flow?

D. Transistors

T6B02 (C)

What electronic component allows current to flow in only one direction?

C. Diode

T6B03 (C)

Which of these components can be used as an electronic switch or amplifier?

C. Transistor

T6B04 (B)

Which of these components is made of three layers of semiconductor material?

B. Bipolar junction transistor

T6B05 (A)

Which of the following electronic components can amplify signals?

A. Transistor

T6B06 (B)

How is a semiconductor diode's cathode lead usually identified?

B. With a stripe

T6B07 (B)

What does the abbreviation "LED" stand for?

B. Light Emitting Diode

T6B08 (A)

What does the abbreviation "FET" stand for?

A. Field Effect Transistor

T6B09 (C)

What are the names of the two electrodes of a diode?

C. Anode and cathode

T6B10 (A)

Which semiconductor component has an emitter electrode?

A. Bipolar transistor

T6B11 (B)

Which semiconductor component has a gate electrode?

B. Field effect transistor

T6B12 (A)

What is the term that describes a transistor's ability to amplify a signal?

A. Gain

T6C01 (C)

What is the name for standardized representations of components in an electrical wiring diagram?

C. Schematic symbols

T6C02 (A)

What is component 1 in figure T1?

A. Resistor

T6C03 (B)

What is component 2 in figure T1?

B. Transistor

T6C04 (C)

What is component 3 in figure T1?

C. Lamp

T6C05 (C)

What is component 4 in figure T1?

C. Battery

T6C06 (B)

What is component 6 in figure T2?

B. Capacitor

T6C07 (D)

What is component 8 in figure T2?

D. Light emitting diode

T6C08 (C)

What is component 9 in figure T2?

C. Variable resistor

T6C09 (D)

What is component 4 in figure T2?

D. Transformer

T6C10 (D)

What is component 3 in figure T3?

D. Variable inductor

T6C11 (A)

What is component 4 in figure T3?

A. Antenna

T6C12 (A)

What do the symbols on an electrical circuit schematic diagram represent?

A. Electrical components

T6C13 (C)

Which of the following is accurately represented in electrical circuit schematic diagrams?

C. The way components are interconnected

T6D01 (B)

Which of the following devices or circuits changes an alternating current into a varying direct current signal?

B. Rectifier

T6D02 (A)

What best describes a relay?

A. A switch controlled by an electromagnet

T6D03 (A)

What type of switch is represented by item 3 in figure T2?

A. Single-pole single-throw

T6D04 (C)

Which of the following can be used to display signal strength on a numeric scale?

C. Meter

T6D05 (A)

What type of circuit controls the amount of voltage from a power supply?

A. Regulator

T6D06 (B)

What component is commonly used to change 120V AC house current to a lower AC voltage for other uses?

B. Transformer

T6D07 (A)

Which of the following is commonly used as a visual indicator?

A. LED

T6D08 (D)

Which of the following is used together with an inductor to make a tuned circuit?

D. Capacitor

T6D09 (C)

What is the name of a device that combines several semiconductors and other components into one package?

C. Integrated circuit

T6D10 (C)

What is the function of component 2 in Figure T1?

C. Control the flow of current

T6D11 (B)

Which of the following is a common use of coaxial cable?

B. Carry RF signals between a radio and antenna

T7A01 (C)

What is the function of a product detector?

C. Detect CW and SSB signals

T7A02 (C)

What type of receiver is shown in Figure T6?

C. Single-conversion superheterodyne

T7A03 (C)

What is the function of a mixer in a superheterodyne receiver?

C. To shift the incoming signal to an intermediate frequency

T7A04 (D)

What circuit is pictured in Figure T7, if block 1 is a frequency discriminator?

D. An FM receiver

T7A05 (D)

What is the function of block 1 if figure T4 is a simple CW transmitter?

D. Oscillator

T7A06 (C)

What device takes the output of a low-powered 28 MHz SSB exciter and produces a 222 MHz output signal?

C. Transverter

T7A07 (B)

If figure T5 represents a transceiver in which block 1 is the transmitter portion and block 3 is the receiver portion, what is the function of block 2?

B. A transmit-receive switch

T7A08 (C)

Which of the following circuits combines a speech signal and an RF carrier?

C. Modulator

T7A09 (B)

Which of the following devices is most useful for VHF weak-signal communication?

B. A multi-mode VHF transceiver

T7A10 (B)

What device increases the low-power output from a handheld transceiver?

B. An RF power amplifier

T7A11 (B)

Which of the following circuits demodulates FM signals?

B. Discriminator

T7A12 (C)

Which term describes the ability of a receiver to discriminate between multiple signals?

C. Selectivity

T7A13 (A)

Where is an RF preamplifier installed?

A. Between the antenna and receiver

T7B01 (D)

What can you do if you are told your FM handheld or mobile transceiver is over deviating?

D. Talk farther away from the microphone

T7B02 (C)

What is meant by fundamental overload in reference to a receiver?

C. Interference caused by very strong signals

T7B03 (D)

Which of the following may be a cause of radio frequency interference?

D. All of these choices are correct

T7B04 (B)

What is the most likely cause of interference to a non-cordless telephone from a nearby transmitter?

B. The telephone is inadvertently acting as a radio receiver

T7B05 (C)

What is a logical first step when attempting to cure a radio frequency interference problem in a nearby telephone?

C. Install an RF filter at the telephone

T7B06 (A)

What should you do first if someone tells you that your station's transmissions are interfering with their radio or TV reception?

A. Make sure that your station is functioning properly and that it does not cause interference to your own television

T7B07 (D)

Which of the following may be useful in correcting a radio frequency interference problem?

D. All of these choices are correct

T7B08 (D)

What should you do if a "Part 15" device in your neighbor's home is causing harmful interference to your amateur station?

D. All of these choices are correct

T7B09 (D)

What could be happening if another operator reports a variable high-pitched whine on the audio from your mobile transmitter?

D. Noise on the vehicle's electrical system is being transmitted along with your speech audio

T7B10 (D)

What might be the problem if you receive a report that your audio signal through the repeater is distorted or unintelligible?

D. All of these choices are correct

T7B11 (C)

What is a symptom of RF feedback in a transmitter or transceiver?

C. Reports of garbled, distorted, or unintelligible transmissions

T7B12 (C)

What does the acronym "BER" mean when applied to digital communications systems?

C. Bit Error Rate

T7C01 (A)

What is the primary purpose of a dummy load?

A. To prevent the radiation of signals when making tests

T7C02 (B)

Which of the following instruments can be used to determine if an antenna is resonant at the desired operating frequency?

B. An antenna analyzer

T7C03 (A)

What, in general terms, is standing wave ratio (SWR)?

A. A measure of how well a load is matched to a transmission line

T7C04 (C)

What reading on an SWR meter indicates a perfect impedance match between the antenna and the feedline?

C. 1 to 1

T7C05 (A)

What is the approximate SWR value above which the protection circuits in most solid-state transmitters begin to reduce transmitter power?

A. 2 to 1

T7C06 (D)

What does an SWR reading of 4:1 mean?

D. An impedance mismatch

T7C07 (C)

What happens to power lost in a feedline?

C. It is converted into heat

T7C08 (D)

What instrument other than an SWR meter could you use to determine if a feedline and antenna are properly matched?

D. Directional wattmeter

T7C09 (A)

Which of the following is the most common cause for failure of coaxial cables?

A. Moisture contamination

T7C10 (D)

Why should the outer jacket of coaxial cable be resistant to ultraviolet light?

D. Ultraviolet light can damage the jacket and allow water to enter the cable

T7C11 (C)

What is a disadvantage of "air core" coaxial cable when compared to foam or solid dielectric types?

C. It requires special techniques to prevent water absorption

T7D01 (B)

Which instrument would you use to measure electric potential or electromotive force?

B. A voltmeter

T7D02 (B)

What is the correct way to connect a voltmeter to a circuit?

B. In parallel with the circuit

T7D03 (A)

How is an ammeter usually connected to a circuit?

A. In series with the circuit

T7D04 (D)

Which instrument is used to measure electric current?

D. An ammeter

T7D05 (D)

What instrument is used to measure resistance?

D. An ohmmeter

T7D06 (C)

Which of the following might damage a multimeter?

C. Attempting to measure voltage when using the resistance setting

T7D07 (D)

Which of the following measurements are commonly made using a multimeter?

D. Voltage and resistance

T7D08 (C)

Which of the following types of solder is best for radio and electronic use?

C. Rosin-core solder

T7D09 (C)

What is the characteristic appearance of a "cold" solder joint?

C. A grainy or dull surface

T7D10 (B)

What is probably happening when an ohmmeter, connected across a circuit, initially indicates a low resistance and then shows increasing resistance with time?

B. The circuit contains a large capacitor

T7D11 (B)

Which of the following precautions should be taken when measuring circuit resistance with an ohmmeter?

B. Ensure that the circuit is not powered

T8A01 (C)

Which of the following is a form of amplitude modulation?

C. Single sideband

T8A02 (A)

What type of modulation is most commonly used for VHF packet radio transmissions?

A. FM

T8A03 (C)

Which type of voice modulation is most often used for long-distance or weak signal contacts on the VHF and UHF bands?

C. SSB

T8A04 (D)

Which type of modulation is most commonly used for VHF and UHF voice repeaters?

D. FM

T8A05 (C)

Which of the following types of emission has the narrowest bandwidth?

C. CW

T8A06 (A)

Which sideband is normally used for 10 meter HF, VHF and UHF single-sideband communications?

A. Upper sideband

T8A07 (C)

What is the primary advantage of single sideband over FM for voice transmissions?

C. SSB signals have narrower bandwidth

T8A08 (B)

What is the approximate bandwidth of a single sideband voice signal?

B. 3 kHz

T8A09 (C)

What is the approximate bandwidth of a VHF repeater FM phone signal?

C. Between 5 and 15 kHz

T8A10 (B)

What is the typical bandwidth of analog fast-scan TV transmissions on the 70 cm band?

B. About 6 MHz

T8A11 (B)

What is the approximate maximum bandwidth required to transmit a CW signal?

B. 150 Hz

T8B01 (D)

Who may be the control operator of a station communicating through an amateur satellite or space station?

D. Any amateur whose license privileges allow them to transmit on the satellite uplink frequency

T8B02 (B) [97.313(a)]

How much transmitter power should be used on the uplink frequency of an amateur satellite or space station?

B. The minimum amount of power needed to complete the contact

T8B03 (A)

Which of the following can be done using an amateur radio satellite?

A. Talk to amateur radio operators in other countries

T8B04 (B)

Which amateur stations may make contact with an amateur station on the International Space Station using 2 meter and 70 cm band amateur radio frequencies?

B. Any amateur holding a Technician or higher class license

T8B05 (D)

What is a satellite beacon?

D. A transmission from a space station that contains information about a satellite

T8B06 (D)

What can be used to determine the time period during which an amateur satellite or space station can be accessed?

D. A satellite tracking program

T8B07 (C)

With regard to satellite communications, what is Doppler shift?

C. An observed change in signal frequency caused by relative motion between the satellite and the earth station

T8B08 (B)

What is meant by the statement that a satellite is operating in "mode U/V"?

B. The satellite uplink is in the 70 cm band and the downlink is in the 2 meter band

T8B09 (B)

What causes "spin fading" when referring to satellite signals?

B. Rotation of the satellite and its antennas

T8B10 (C)

What do the initials LEO tell you about an amateur satellite?

C. The satellite is in a Low Earth Orbit

T8B11 (C)

What is a commonly used method of sending signals to and from a digital satellite?

C. FM Packet

T8C01 (C)

Which of the following methods is used to locate sources of noise interference or jamming?

C. Radio direction finding

T8C02 (B)

Which of these items would be useful for a hidden transmitter hunt?

B. A directional antenna

T8C03 (A)

What popular operating activity involves contacting as many stations as possible during a specified period of time?

A. Contesting

T8C04 (C)

Which of the following is good procedure when contacting another station in a radio contest?

C. Send only the minimum information needed for proper identification and the contest exchange

T8C05 (A)

What is a grid locator?

A. A letter-number designator assigned to a geographic location

T8C06 (C)

For what purpose is a temporary "1 by 1" format (letter-number-letter) call sign assigned?

C. For operations in conjunction with an activity of special significance to the amateur community

T8C07 (B) [97.215(c)]

What is the maximum power allowed when transmitting telecommand signals to radio controlled models?

B. 1 watt

T8C08 (C) [97.215(a)]

What is required in place of on-air station identification when sending signals to a radio control model using amateur frequencies?

C. A label indicating the licensee's name, call sign and address must be affixed to the transmitter

T8C09 (C)

How might you obtain a list of active nodes that use VoIP?

C. From a repeater directory

T8C10 (D)

How do you select a specific IRLP node when using a portable transceiver?

D. Use the keypad to transmit the IRLP node ID

T8C11 (A)

What name is given to an amateur radio station that is used to connect other amateur stations to the Internet?

A. A gateway

T8D01 (D)

Which of the following is an example of a digital communications method?

D. All of these choices are correct

T8D02 (A)

What does the term APRS mean?

A. Automatic Position Reporting System

T8D03 (D)

Which of the following is normally used when sending automatic location reports via amateur radio?

D. A Global Positioning System receiver

T8D04 (C)

What type of transmission is indicated by the term NTSC?

C. An analog fast scan color TV signal

T8D05 (B)

Which of the following emission modes may be used by a Technician Class operator between 219 and 220 MHz?

B. Data

T8D06 (B)

What does the abbreviation PSK mean?

B. Phase Shift Keying

T8D07 (D)

What is PSK31?

D. A low-rate data transmission mode

T8D08 (D)

Which of the following may be included in packet transmissions?

D. All of these choices are correct

T8D09 (C)

What code is used when sending CW in the amateur bands?

C. International Morse

T8D10 (D)

Which of the following can be used to transmit CW in the amateur bands?

D. All of these choices are correct

T8D11 (C)

What is a "parity" bit?

C. An extra code element used to detect errors in received data

T9A01 (C)

What is a beam antenna?

C. An antenna that concentrates signals in one direction

T9A02 (B)

Which of the following is true regarding vertical antennas?

B. The electric field is perpendicular to the Earth

T9A03 (B)

Which of the following describes a simple dipole mounted so the conductor is parallel to the Earth's surface?

B. A horizontally polarized antenna

T9A04 (A)

What is a disadvantage of the "rubber duck" antenna supplied with most handheld radio transceivers?

A. It does not transmit or receive as effectively as a full-sized antenna

T9A05 (C)

How would you change a dipole antenna to make it resonant on a higher frequency?

C. Shorten it

T9A06 (C)

What type of antennas are the quad, Yagi, and dish?

C. Directional antennas

T9A07 (A)

What is a good reason not to use a "rubber duck" antenna inside your car?

A. Signals can be significantly weaker than when it is outside of the vehicle

T9A08 (C)

What is the approximate length, in inches, of a quarter-wavelength vertical antenna for 146 MHz?

C. 19

T9A09 (C)

What is the approximate length, in inches, of a 6 meter 1/2-wavelength wire dipole antenna?

C. 112

T9A10 (C)

In which direction is the radiation strongest from a half-wave dipole antenna in free space?

C. Broadside to the antenna

T9A11 (C)

What is meant by the gain of an antenna?

C. The increase in signal strength in a specified direction when compared to a reference antenna

T9B01 (B)

Why is it important to have a low SWR in an antenna system that uses coaxial cable feedline?

B. To allow the efficient transfer of power and reduce losses

T9B02 (B)

What is the impedance of the most commonly used coaxial cable in typical amateur radio installations?

B. 50 ohms

T9B03 (A)

Why is coaxial cable used more often than any other feedline for amateur radio antenna systems?

A. It is easy to use and requires few special installation considerations

T9B04 (A)

What does an antenna tuner do?

A. It matches the antenna system impedance to the transceiver's output impedance

T9B05 (D)

What generally happens as the frequency of a signal passing through coaxial cable is increased?

D. The loss increases

T9B06 (B)

Which of the following connectors is most suitable for frequencies above 400 MHz?

B. A Type N connector

T9B07 (C)

Which of the following is true of PL-259 type coax connectors?

C. They are commonly used at HF frequencies

T9B08 (A)

Why should coax connectors exposed to the weather be sealed against water intrusion?

A. To prevent an increase in feedline loss

T9B09 (B)

What might cause erratic changes in SWR readings?

B. A loose connection in an antenna or a feedline

T9B10 (C)

What electrical difference exists between the smaller RG-58 and larger RG-8 coaxial cables?

C. RG-8 cable has less loss at a given frequency

T9B11 (C)

Which of the following types of feedline has the lowest loss at VHF and UHF?

C. Air-insulated hard line

T0A01 (B)

Which is a commonly accepted value for the lowest voltage that can cause a dangerous electric shock?

B. 30 volts

T0A02 (D)

How does current flowing through the body cause a health hazard?

D. All of these choices are correct

T0A03 (C)

What is connected to the green wire in a three-wire electrical AC plug?

C. Safety ground

T0A04 (B)

What is the purpose of a fuse in an electrical circuit?

B. To interrupt power in case of overload

T0A05 (C)

Why is it unwise to install a 20-ampere fuse in the place of a 5-ampere fuse?

C. Excessive current could cause a fire

T0A06 (D)

What is a good way to guard against electrical shock at your station?

D. All of these choices are correct

T0A07 (D)

Which of these precautions should be taken when installing devices for lightning protection in a coaxial cable feedline?

D. Ground all of the protectors to a common plate which is in turn connected to an external ground

T0A08 (C)

What is one way to recharge a 12-volt lead-acid station battery if the commercial power is out?

C. Connect the battery to a car's battery and run the engine

T0A09 (C)

What kind of hazard is presented by a conventional 12-volt storage battery?

C. Explosive gas can collect if not properly vented

T0A10 (A)

What can happen if a lead-acid storage battery is charged or discharged too quickly?

A. The battery could overheat and give off flammable gas or explode

T0A11 (C)

Which of the following is good practice when installing ground wires on a tower for lightning protection?

C. Ensure that connections are short and direct

T0A12 (D)

What kind of hazard might exist in a power supply when it is turned off and disconnected?

D. You might receive an electric shock from stored charge in large capacitors

T0A13 (A)

What safety equipment should always be included in home-built equipment that is powered from 120V AC power circuits?

A. A fuse or circuit breaker in series with the AC "hot" conductor

T0B01 (C)

When should members of a tower work team wear a hard hat and safety glasses?

C. At all times when any work is being done on the tower

T0B02 (C)

What is a good precaution to observe before climbing an antenna tower?

C. Put on a climbing harness and safety glasses

T0B03 (D)

Under what circumstances is it safe to climb a tower without a helper or observer?

D. Never

T0B04 (C)

Which of the following is an important safety precaution to observe when putting up an antenna tower?

C. Look for and stay clear of any overhead electrical wires

T0B05 (C)

What is the purpose of a gin pole?

C. To lift tower sections or antennas

T0B06 (D)

What is the minimum safe distance from a power line to allow when installing an antenna?

D. So that if the antenna falls unexpectedly, no part of it can come closer than 10 feet to the power wires

T0B07 (C)

Which of the following is an important safety rule to remember when using a crank-up tower?

C. This type of tower must never be climbed unless it is in the fully retracted position

T0B08 (C)

What is considered to be a proper grounding method for a tower?

C. Separate eight-foot long ground rods for each tower leg, bonded to the tower and each other

T0B09 (C)

Why should you avoid attaching an antenna to a utility pole?

C. The antenna could contact high-voltage power wires

T0B10 (C)

Which of the following is true concerning grounding conductors used for lightning protection?

C. Sharp bends must be avoided

T0B11 (B)

Which of the following establishes grounding requirements for an amateur radio tower or antenna?

B. Local electrical codes

T0C01 (D)

What type of radiation are VHF and UHF radio signals?

D. Non-ionizing radiation

T0C02 (B)

Which of the following frequencies has the lowest Maximum Permissible Exposure limit?

B. 50 MHz

T0C03 (C)

What is the maximum power level that an amateur radio station may use at VHF frequencies before an RF exposure evaluation is required?

C. 50 watts PEP at the antenna

T0C04 (D)

What factors affect the RF exposure of people near an amateur station antenna?

D. All of these choices are correct

T0C05 (D)

Why do exposure limits vary with frequency?

D. The human body absorbs more RF energy at some frequencies than at others

T0C06 (D)

Which of the following is an acceptable method to determine that your station complies with FCC RF exposure regulations?

D. All of these choices are correct

T0C07 (B)

What could happen if a person accidentally touched your antenna while you were transmitting?

B. They might receive a painful RF burn

T0C08 (A)

Which of the following actions might amateur operators take to prevent exposure to RF radiation in excess of FCC-supplied limits?

A. Relocate antennas

T0C09 (B)

How can you make sure your station stays in compliance with RF safety regulations?

B. By re-evaluating the station whenever an item of equipment is changed

T0C10 (A)

Why is duty cycle one of the factors used to determine safe RF radiation exposure levels?

A. It affects the average exposure of people to radiation

T0C11 (C)

What is meant by "duty cycle" when referring to RF exposure?

C. The ratio of on-air time to total operating time of a transmitted signal

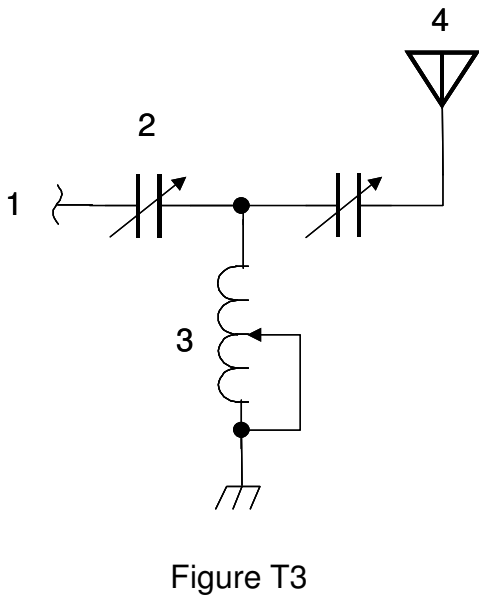
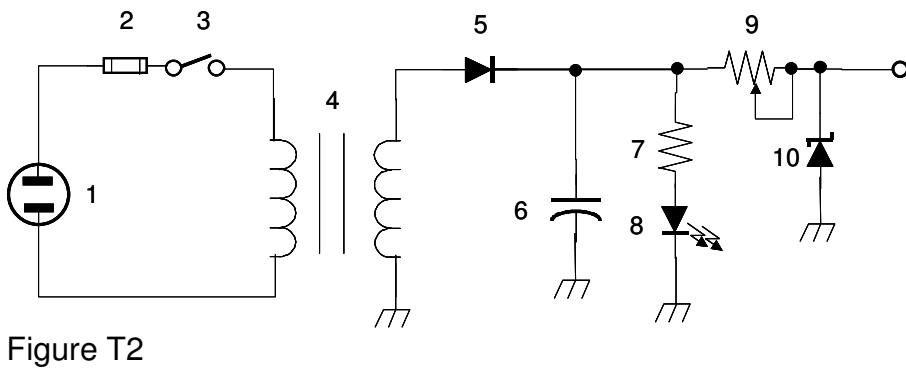
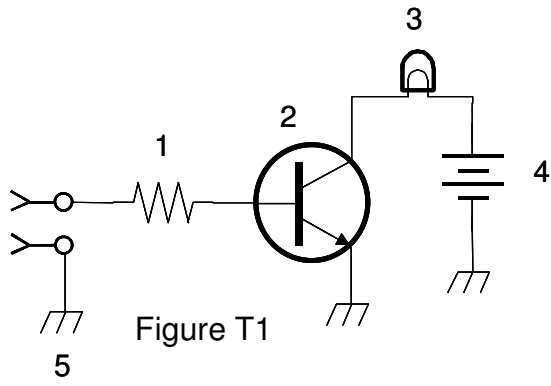

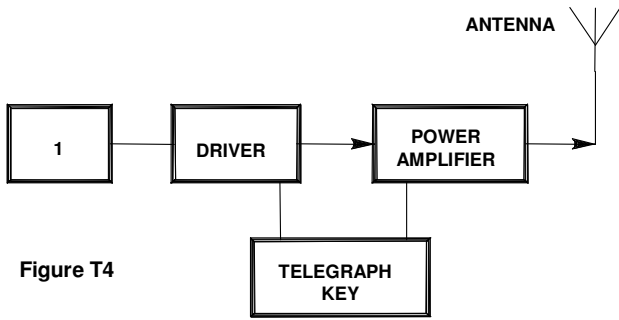

Figure T4

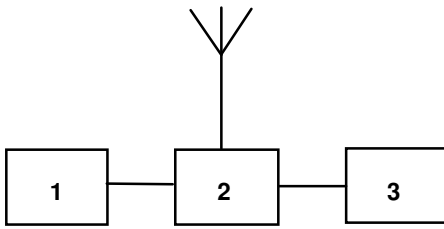

Figure T5

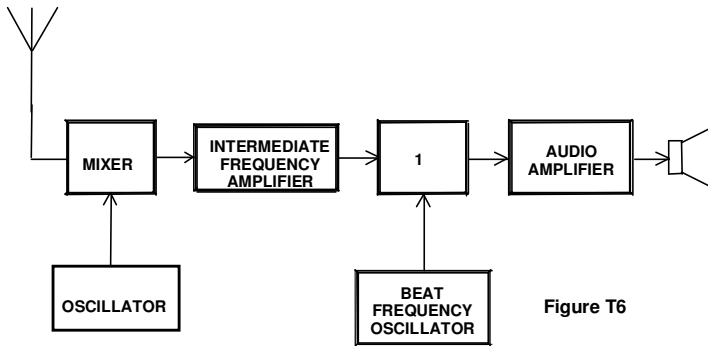

Figure T6

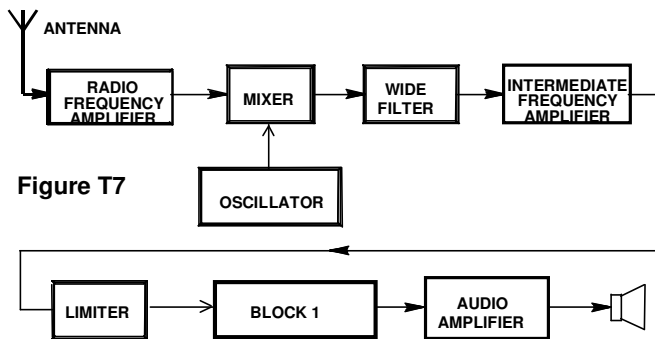

Figure T7